

HIGHLEAD YXP-18
LEATHER SKIVING MACHINE

INSTRUCTION
MANUAL & PARTS LIST

General Description and Instruction

I. Application

This machine is a special equipment for making of leather goods. It is Widely used for the shaping of slope edge and the even shiving of warios Parts for leather material and PU material goods such as leather shoes, Gloves,bags,wallet.belt,macket and suitcase,etc.

II. Features

- 1.Rational design,compact in structure,easy operation,simple adjustment and good performance.
- 2.Low noise level because of adoption of low noise precision bearings and making at utmost care.
- 3.With knife sharpener.Driven through clutch level, easy operation and saving on energy.

4.With autonatic belt stretcher,safety and reliability in criving.

5.With automatic of spare parts.

6.Easy replacement cleaning.

III. Main specifications

- 1.Motor:370-550W,1400rpm
- 2.Knife size: $\Phi 118 \times \Phi 114 \times 52$ (mm)
- 3.Knife speed:1270rpm
- 4.Knife axial displacement:30mm
- 5.Feed wheel speed:62,99,132rpm
- 6.Feeding speed:9247,14766,19688 mm/min
- 7.Skiving width:10-50mm
- 8.Abrasive wheel size: $\Phi 70 \times \Phi 16 \times 8$ (mm)
- 9.Noise level:<60dB(A)
- 10.Weight:40kg

IV. Instllation and adjustment

1. Installation

When its being installed,first assemble the stand and work table,then fix the machine on the table by two pairs of hinge,lastly fix the desired motor on the rear side of the table and fit up V.belt.Before being put into operation,it must be trialoperated and it is certain that the turn direction of the knife is

correct(seeing knife rightwards it turns clockwise)and the machine functions normally.

2.Adjustment

It is necessary to make some adjustments according to the skiving requirements.

1).When the desired skiving thick of the parts for leather goods varies, please adjust the height of presser foot(1-16)correspondingly.In the case of even skiving and slope skiving,please respectively use presser foot A and presser foot B;and when a U shape skiving is required,please use presser foot C.Skiving width can be adjusted through the ruler(1-31)

2).When it is necessary to change the feeding speed,please change the position of the V.belt on the belt pulley.

3).The clearance between the feed wheel and the knife can be adjusted by turning the handles (3 - 64&3 - 67) . When equal or different clearance along the knife edge is required,please turn the handle(3 - 67).Turning the handle(3 - 64)makes the clearance equally decreased or increased.Be sure that feed wheel can' t collide with knife.

4). When knife is blunt,set the clutch leveler at work position,and then turn the screw(3 - 36)slowly to grind the knife.

5).After the knife is worn , move the knife axis leftwards slightly by turning the knob . The proper distance between the right surface of the presser foot and the knife edge is 0.1 - 0.5mm.

6).Through pushing or pulling the cleaner(2-1)by accessory(4-4) , the axial position of cleaner in the knife can be adjusted and the desired cleaning result for different material scrap can be got.

V.Maintenance

1.Before operation,be sure the machine is in a good condition.

2.Periodically feed oil on the moving parts.

3.sharpen the knife when it is blunt.

4.If there is abnormal noise or bard runing of the machine , it must be stopped and checked at once . If necessary , please have it repairde by a qualified technician.Don' t go into operation until the machine has arrived at the good condition.

5.keep the machine clean.

1. PRESSER FOOT AND OUTER ATTACHMENTS

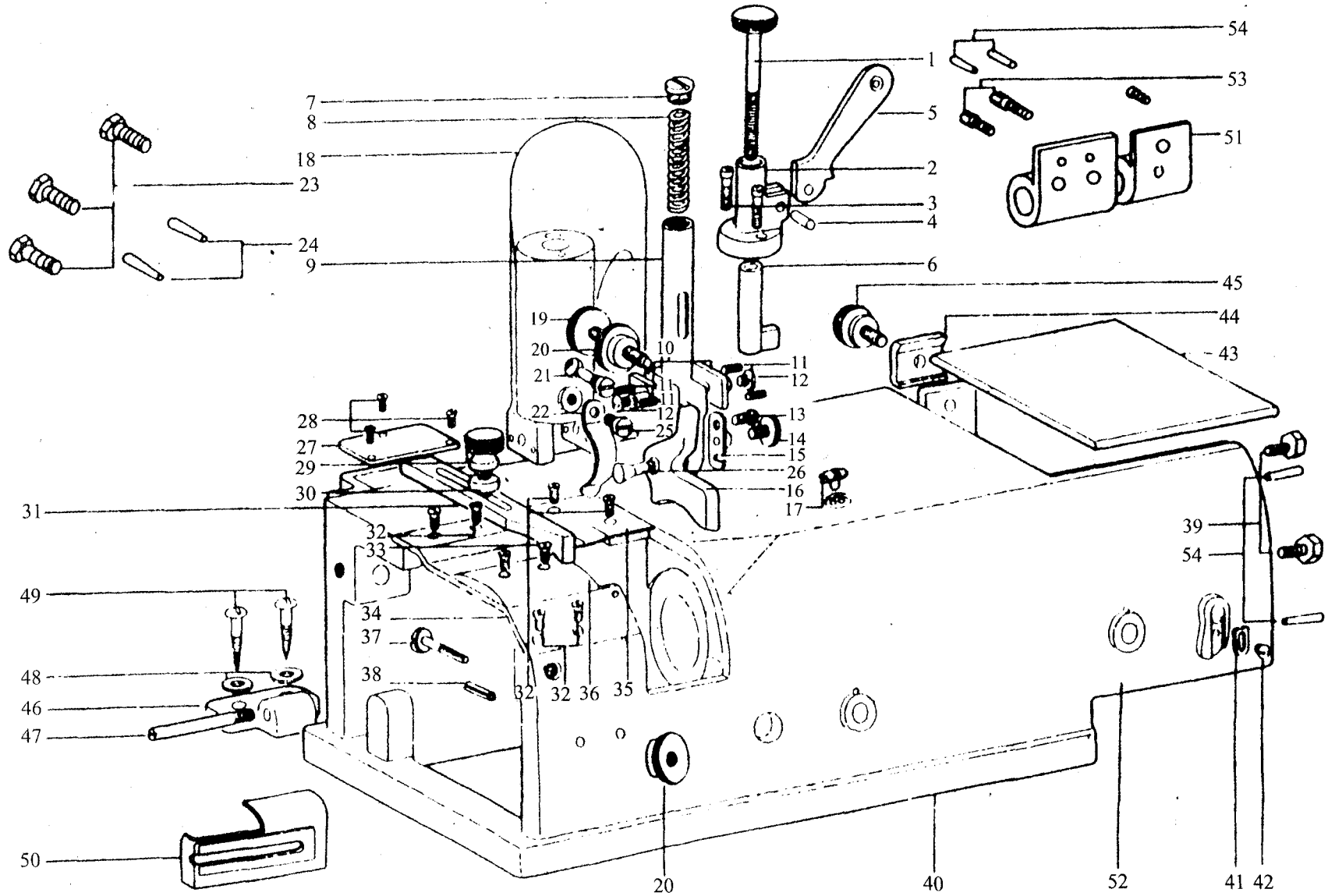

Item	Part No.	Description	Quan	Romar
1.1	1157	Presser bar adjusting screw	1	
1.2	1156	Presser bar lifter bracket	2	9223
1.3	3/16" x 28 x 15 ^p	Presser bar lifter bracket screw	2	9223
1.4	5 x 16 ^p	Presser bar lifter pin	1	
1.5	1153	Presser bar lifter	1	
1.6	1155	Presser bar lifter lever	1	
1.7	1150	Presser bar cover screw	1	
1.8	1151	Presser bar spring	1	
1.9	1145	Presser bar	1	
1.10	1148	Presser foot side plates	2	
1.11	9 x 64" x 10 ^p	Presser foot side plates adjusting screws	4	
1.12	3/16" x 28 x 6 ^p	Presser foot side plates screws	1	
1.13	3/16" x 28 x 10 ^p	Presser foot shaft hook metal hinge screw	1	
1.14	1144	presser foot shaft hook metal set screw	1	
1.15	1142	presser foot shaft hook metal	1	
1.16	1140	Presser foot 50mm	1	
1.17	1007	Oil cup	1	
1.18	1001	Arm	1	
1.19	1085	Presser foot adjusting screw	1	3.67
1.20	1086	Presser foot adjxustabe screw nuts	2	3.68
1.21	1152	Presser bar spring pin	1	
1.22	1140	Presser foot spring	1	
1.23	3/8" x 16 x 25 ^p	Inner hexagonal screw	1	
1.24	Φ6 x 25 ^p	Taper pin	1	
1.25	3/16" x 32 x 10 ^p	Presser foot spring screw-	1	
1.26	1141	Presser foot shaft	1	
1.27	1122	Worm shamber plate	1	
1.28	9/64" x 40 x 7.5 ^p	Screws	1	
1.29	1009	Ruler set screw	1	
1.30	1008	Ruler set screw washer	1	
1.31	1006	Ruler	1	
1.32	11/64" x 40 x 9 ^p	Slide plate screws	6	
1.33	11/64" x 40 x 7 ^p	Slide plate screws	2	
1.34	1003	Slide plate A	1	
1.35	1004	Slide plate B	1	
1.36	1005	Slide plate C	1	
1.37	15/64" x 28 ^p	Waster feeder screw	1	
1.38	6 x 25.4 ^p	Waster feeder stop pin	1	
1.39	5/16" x 24 x 21 ^p	Hexagon slotted screy (Base plate)	2	
1.40	1002	Bed	1	233
1.41	1036	Belt cover plate	1	
1.42	9/64" x 40 x 6	Belt cover plate screw	1	
1.43	1037	Belt cover lid	1	
1.44	1038	Belt cover lid stopper	1	
1.45	1009	Ruler set screw	1	1.29
1.46	2001	Hinges	2	
1.47	2002	Hinge pins	2	
1.48	18 x 6.3 x 1.6	Hinge set screw washers	4	
1.49	6 x 30	Hinge set screws	4	
1.50	1105	Waste feeder metals(SET)	1	

Item	Part No.	Description	Quan	Romar
1.51	2003	Fransmission shelf	1	
1.52	2004	Base plate	1	3.47
1.53	1/4" x 20 x 20 ^p	Set screw (Transmiasion shalt)	2	
1.54	Φ4 x 22 ^p	Tape pin	4	3.83

2. KNIFE AND RELATED PARTS

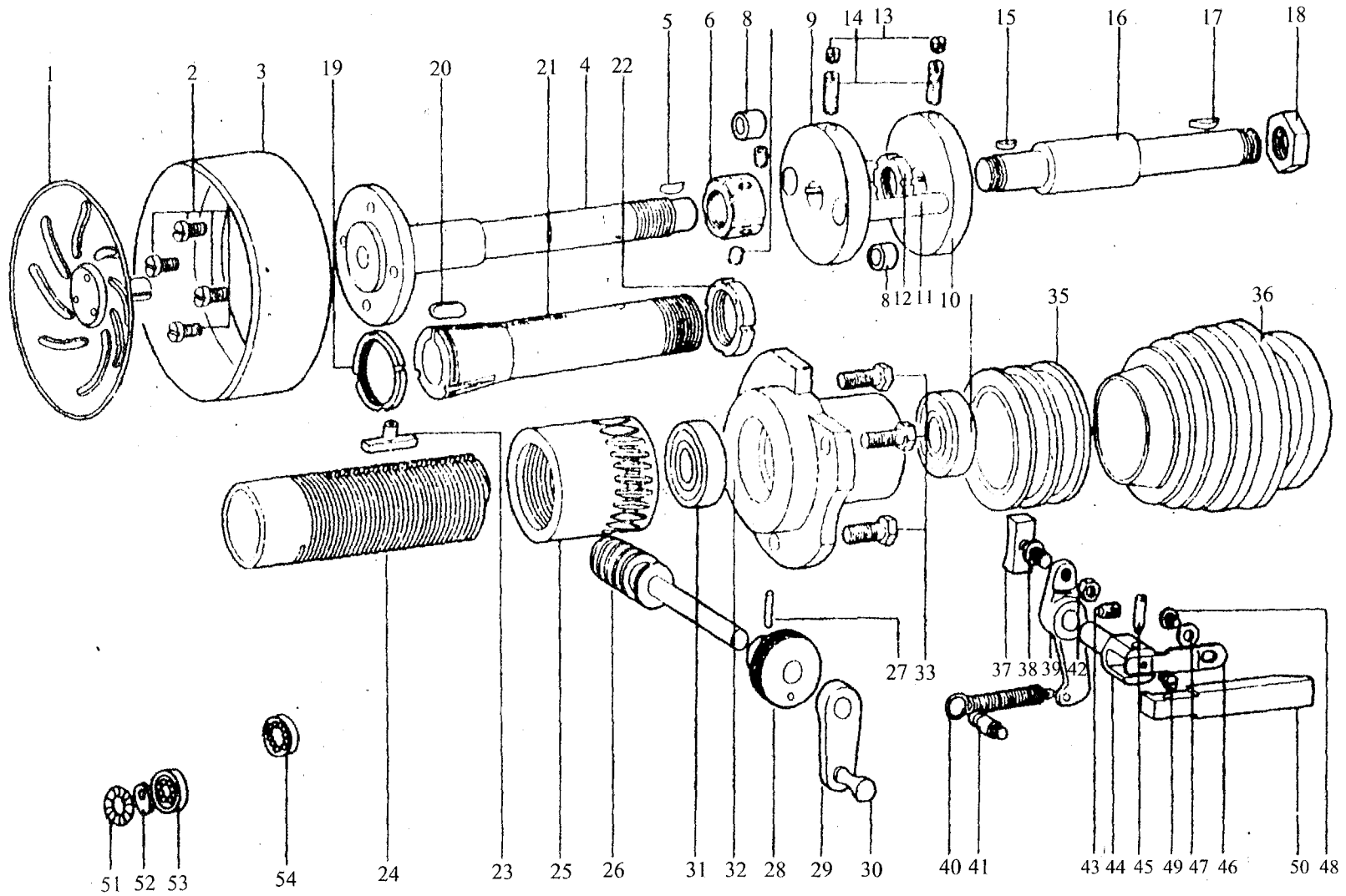

Item	Part No.	Description	Quan	Romar
2.1	1021	leather peeled cover	1	
2.2	M6 p1.0 × 10 ^p	Knife set screws	4	
2.3	1010	Knife	1	
2.4	1011	Knife shaft	1	
2.5	3 × 13	Knife shaft key	1	
2.6	Φ28 × M16 × 7 × P1.5	Knife shaft nuts	2	
2.8	1023	Rubber bushings	2	
2.9	1015	Puller shaft flange holder	1	
2.10	1033	Pulley shaft flange	1	
2.11	1034	Flange shafts	2	
2.12	Φ28 × M18 × 7 × P1.5	Pulley shaft flange nut	1	
2.13	9/32" × 28 × 4.5	Pulley shaft flange screws(B)	2	
2.14	9/32" × 28 × 18	Pulley shaft flange screws(A)	2	
2.15	3 × 10	Pulley shaft key(small)	1	
2.16	1031	Pulley shaft	1	
2.17	3 × 16	Pulley shaft key	1	
2.18	M16p × P1.5	Hexagonal nut(A)	1	
2.23	1020	Knife shaft lead pipe key	1	
2.24	1013	knife shaft lead pipe	1	
2.25	1014	Knife shaft worm wheel	1	
2.26	1016	Knife shaft worm	1	
2.27	3 × 18 ^p	Taper pin	1	
2.28	1017	Knife adjusting knob	1	
2.29	1018	Knife adjusting handle	1	
2.30	1020	Knife adjusting handle Knob	1	
2.31	6203Z	pulley shaft bearings	1	
2.32	6023Z	Pulley shaft metal	1	
2.33	5/16" × 24 × 21 ^p	pulley shaft metal screws	3	1.39
2.34		Pulley shaft bearing	1	
2.35	1035	Clutch	1	
2.36	1030	Pulley	1	
2.37	1049	Clutch slide block	1	
2.38	1040	Clutch slide block screw	1	
2.39	1043	Clutch arm	1	
2.40	1024	Clutch spring	1	
2.41	1046	Clutch spring hook	1	
2.42	1/4" × 40	Clutch slide block screw nut	1	
2.43	15/64" × 28 × 8 ^p	Clutch lever screw	1	
2.44	1041	Clutch lever shaft	1	
2.45	1160	Clutch arm screw	1	
2.46	1042	Clutch lever spring	1	
2.47		Clutch lever spring washer	1	
2.48	9/64" × 40 × 6 ^p	Clutch lever spring hinge screw	1	
2.49	9/64" × 40 × 6 ^p	Clutch lever spring screw	1	
2.50	1039	Clutch lever	1	
2.51	NTB2035	Trust bearing	1	
2.52	20 × 35 × 1	Flat gasket	1	
2.53	6004 ZZ	Bearing	1	
2.54	6023 ZZ	Bearing	1	2.31

3. GRINDSTONE AND ROLLER RELATED PARTS

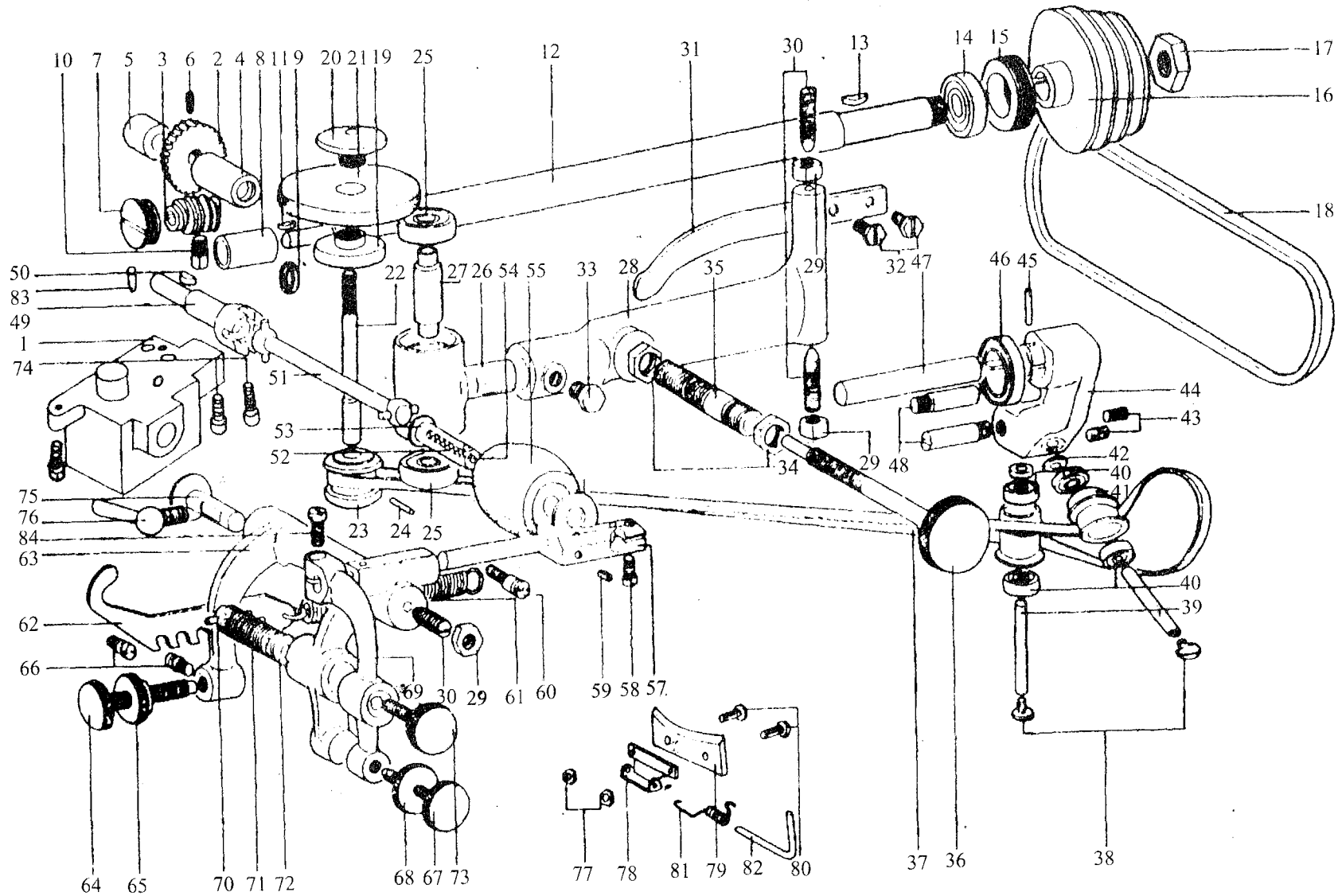

Item	Part No.	Description	Quan	Romar
3.1		Worm wheel box	1	
3.2	1116	Main shaft worm gear Wheel	1	
3.3	1115	Main shaft worm gear	1	
3.4	1119	Roller driving shaft Metal	1	
3.5	1120	Roller driving shaft metal(2)	1	
3.6	9/64" x 40 x 90°	Main shaft worm gear Wheel screw	1	
3.7	1123	Main shaft worm gear Chamber cover screw	1	
3.8		Main shaft front bushing	1	
3.9	121803	Main shaft worm gear chamber oil seal	1	
3.10	1124	Main shaft worm gear Chamber screw	1	
3.11	2.5 x 10	main shaft key(1)	1	
3.12	1110	main shaft	1	
3.13	3 x 16	Main shaft key(2)	1	
3.14	6002 ZZ	main shaft bearing	1	
3.15	M63 x 10 x P1.5	Main shaft bearing holder screw	1	
3.16	1111	Main shaft pulley	1	
3.17	M14 x P1.5	Hexagonal nut B	1	
3.18	3 starK20	Main shaft belt	1	
3.19	1051	Grindstone set screw	1	
3.20	1052	Grindstone set screw nut	1	
3.21	1050	Grindstone	1	
3.22	1053	Grindstone shaft	1	
3.23		Grindstone shaft pulley	1	
3.24	2.5 x 20	Grindstone shaft pulley taper pin	1	
3.25	6200 Z	Grindstone shaft bearing	1	
3.26	1056	Grindstone shaft bracket	1	
3.27	1055	Grindstone shaft bearing roller	2	
3.28	1057	Grindstone shaft bracket arm	1	
3.29	5/16" x 24	Grindstone shaft bracket arm center screw nuts	1	
3.30	1731	Grindstone shaft bracket arm center screws	3	
3.31	1069	Grindstone shaft bracket arm spring	1	
3.32	15/64" x 24 x 14°	Grindstone shaft bracket arm spring screws	2	
3.33	5/16" x 24 x 14°	Grindstone shaft bracket screw	1	
3.34	1/2" x 28	Grindstone adjusting screw pipe nuts	2	
3.35	1066	Grindstone adjusting screw pipe	1	
3.36	1058	Grindstone adjusting screw	1	
3.37	1059	Grindstone shaft belt	1	
3.38		Belt guide pulley screws	1	
3.39	1063	Belt guide pulley shaft	2	
3.40	626 Z	Belt guide pulley bearings	4	
3.41	1062	Belt guide pulley	2	
3.42	1064	Belt guide pulley washers	2	

Item	Part No.	Description	Quan	Romar
3.43	15/64" x 28 x 8°	Belt guide pulley shaft screws	2	
3.44	1060	Belt guide bracket	1	
3.45	3 x 18	Belt guide bracket taper pin	1	2.27
3.46	1067	Belt guide bracket spring	1	
3.47	1061	Belt guide bracket shaft	1	
3.48	1065	Belt guide bracket turning stoppers	2	
3.49	1118	Roller driving shaft	1	
3.50	3 x 13	Roller driving shaft key	1	
3.51	1121	Roller driving shaft joint	1	
3.52	1094	Roller shaft oil wick	1	
3.53	1081	Roller shaft	1	
3.54		Roller shaft oil seal plug	1	
3.55	1080	Roller	1	
3.56	1082	Roller washer	1	
3.57	1083	Roller bracket	1	
3.58	15/64" x 28 x 10°	Roller shaft screw	1	
3.59	11/64" x 40 x 3.5°	screw	1	
3.60	1098	Waste clear metal shaft screw spring hooks(2)	1	
3.61	1095	Roller bracket arm spring	1	
3.62	1096	Roller bracket arm spring hook metal	1	
3.63	1091	Roller bracket arm	1	
3.64	1092	Roller bracket arm adjusting screw	1	
3.65	1093	Roller bracket arm adjusting screw nut	1	
3.66	1097	Roller bracket arm spring hooks(1)	2	
3.67	1085	Roller bracket turning arm adjusting screw	1	
3.68	1086	Roller bracket turning arm adjusting screw nut	1	
3.69	1084	Roller bracket turning arm	1	
3.70	1088	Roller bracket turning arm spring stopper	1	
3.71	1087	Roller bracket turning arm spring	1	
3.72	1090	Roller bracket turning arm spring nut	1	
3.73	1089	Roller bracket turning arm spring adjusting screw	1	
3.74	1/4 x 20 x 20°	Set screw	3	1.53
3.75	1099	Roller bracket arm center pin	1	
3.76	1100	Roller bracket arm center pin screw	1	
3.77	9/64" x 10	Waste clear metal leather nuts	2	
3.78	1104	Waste clear metal	1	
3.79	1104	Waste clear metal leather	1	
3.80	9/64" x 10	Waste clear metal leather screws	2	
3.81	1103	Waste clear metal spring	1	
3.82	1102	Waste clear metal shaft	1	1.54
3.83	Φ4 x 22°	Taper pin	1	
3.84		Roller shaft screws	1	

4. ACCESSORIES

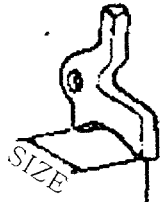
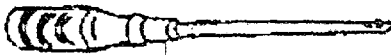
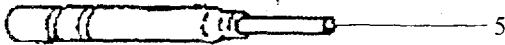
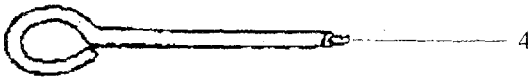

A 40m/m
B 30m/m
C 25m/m

Item	Part No.	Description	Quan
4.1	3001	Grindstone dresser	1
4.2	3002	Grindstone nut spanner	1
4.3	3004	Knife shaft spanner	1
4.4	3005	Knife inter cover remover	1
4.5	3006	Bar type grindstone	1
4.6	3007	Screw driver large	1
4.7	3008	Oiler	
4.16A	1140A	Presser foot 50 mm	1
4.16B	1140B	Presser foot 30 mm	1
4.16C	1140C	Presser foot 25 mm	1
Accessories			
1.47	2002	Hinge pins	2
1.46	2001	Hinges	2
1.48	15 × 6.3 × 1.	Hinge set screw washers	2
1.49	6 × 30	Hinge set screw	4
2.29	1018	Knife adjusting handle	1
2.30	1019	Adjusting handle	1
4.5	3006	Bar type grindstone	1